

Version : 2.0

<p>TECHNICAL SPECIFICATION</p> <p>MODEL NO : PD104VT3</p>

Customer's Confirmation

Customer _____

Date _____

By _____

PVI's Confirmation

Dep	FAE	Panel Design	Electronic Design	Mechanical Design	Product Verification	Prepared by
SIGN	劉豐發 1/19/06	何合理 1/15/06	楊文輝 1/11/06 施建基 1/11/06	申峰 1/10/06	張永明 1/14/06	楊卓欣 1/13/06

TECHNICAL SPECIFICATION**CONTENTS**

NO.	ITEM	PAGE
-	Cover	1
-	Contents	2
1	Application	3
2	Features	3
3	Mechanical Specifications	3
4	Mechanical Drawing of TFT-LCD module	4
5	Input / Output Terminals	6
6	Absolute Maximum Ratings	8
7	Electrical Characteristics	8
8	Pixel Arrangement	14
9	Power On Sequence	14
10	Optical Characteristics	15
11	Handling Cautions	18
12	Reliability Test	19
13	Block Diagram	20
14	Packing Diagram	21
-	Revision History	22

1. Application

This data sheet applies to a color TFT LCD module, PD104VT3.

PD104VT3 module applies to OA product, car TV(must use Analog to Digital drive board), which require high quality flat panel display. If you must use in high reliability environment can't over reliability test condition.

Prime View assume no responsibility for any damage resulting from the use of the device which dose not comply with the instructions and the precautions in these specification sheet.

2. Features

- . Support the DENB mode
- . Image Reversion : Up/Down and Left/Right
- . Amorphous silicon TFT LCD panel with back-light unit
- . Pixel in stripe configuration
- . Slim and compact, designed for O/A application
- . Display Colors : 262,144 colors
- . Optimum Viewing Direction : 6 o'clock
- . +3.3V DC supply voltage for TFT LCD panel driving
- . Backlight driving DC/AC inverter not included in this module
- . TTL transmission interface
- . Wide viewing angle

3. Mechanical Specifications

Parameter	Specifications	Unit
Screen Size	26.4(diagonal)	cm
	10.4 (diagonal)	inch
Display Format	640x(R, G, B)x480	dot
Display Colors	262,144	
Active Area	211.2(H)x158.4(V)	mm
Pixel Pitch	0.330(H)x0.330(V)	mm
Pixel Configuration	Stripe	
Outline Dimension	243.0(w)x185.1 (H)x12.5 (D)	mm
Weight	516±20	g
Back-light	CCFL, 2 tubes	
Surface treatment	Anti-glare and Wide View film	
Display mode	Normally white	

4.Mechanical Drawing of TFT-LCD Module

Outline Drawing : Front View (unit mm)

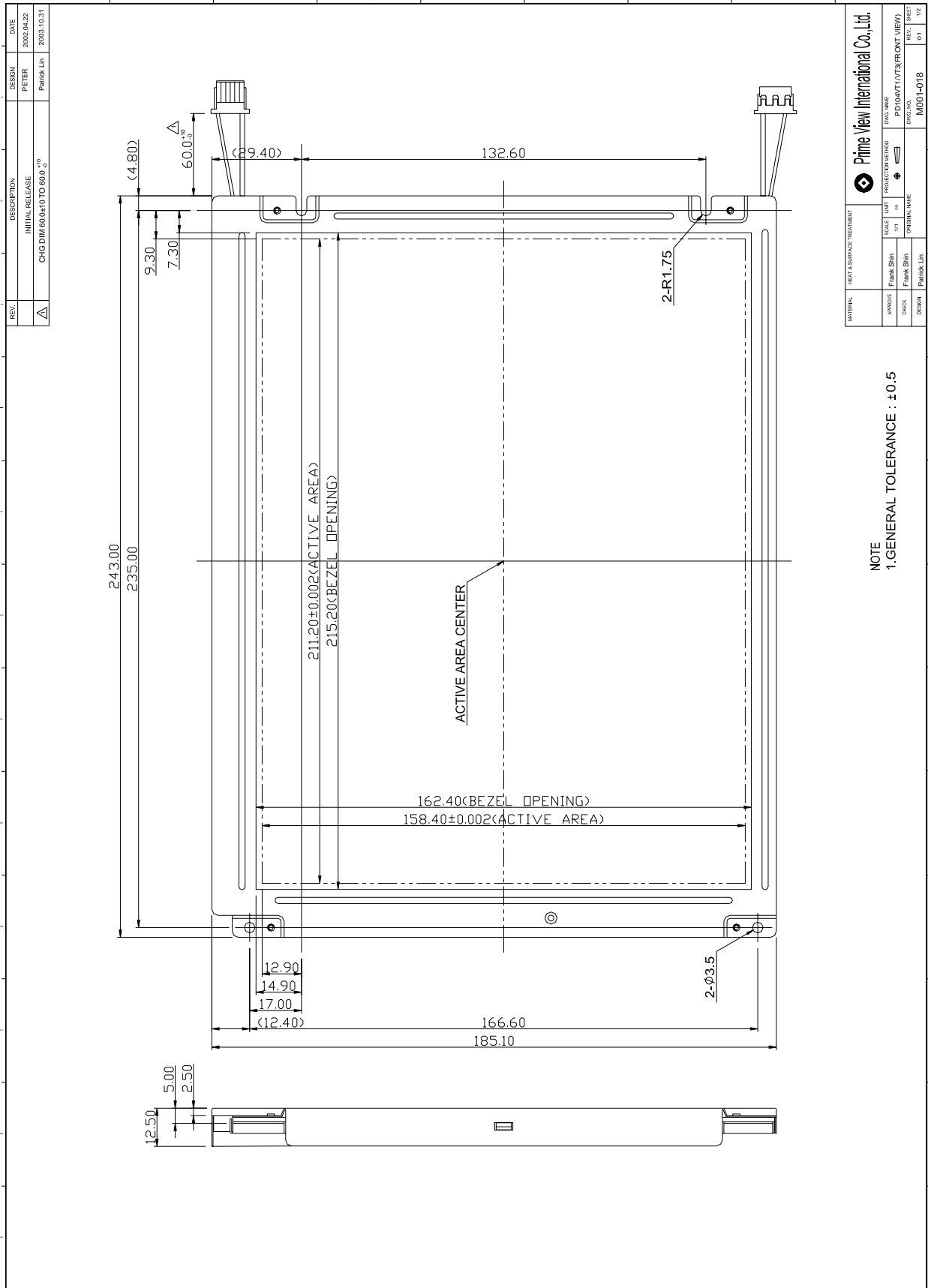

Outline Drawing : Rear View (unit mm)

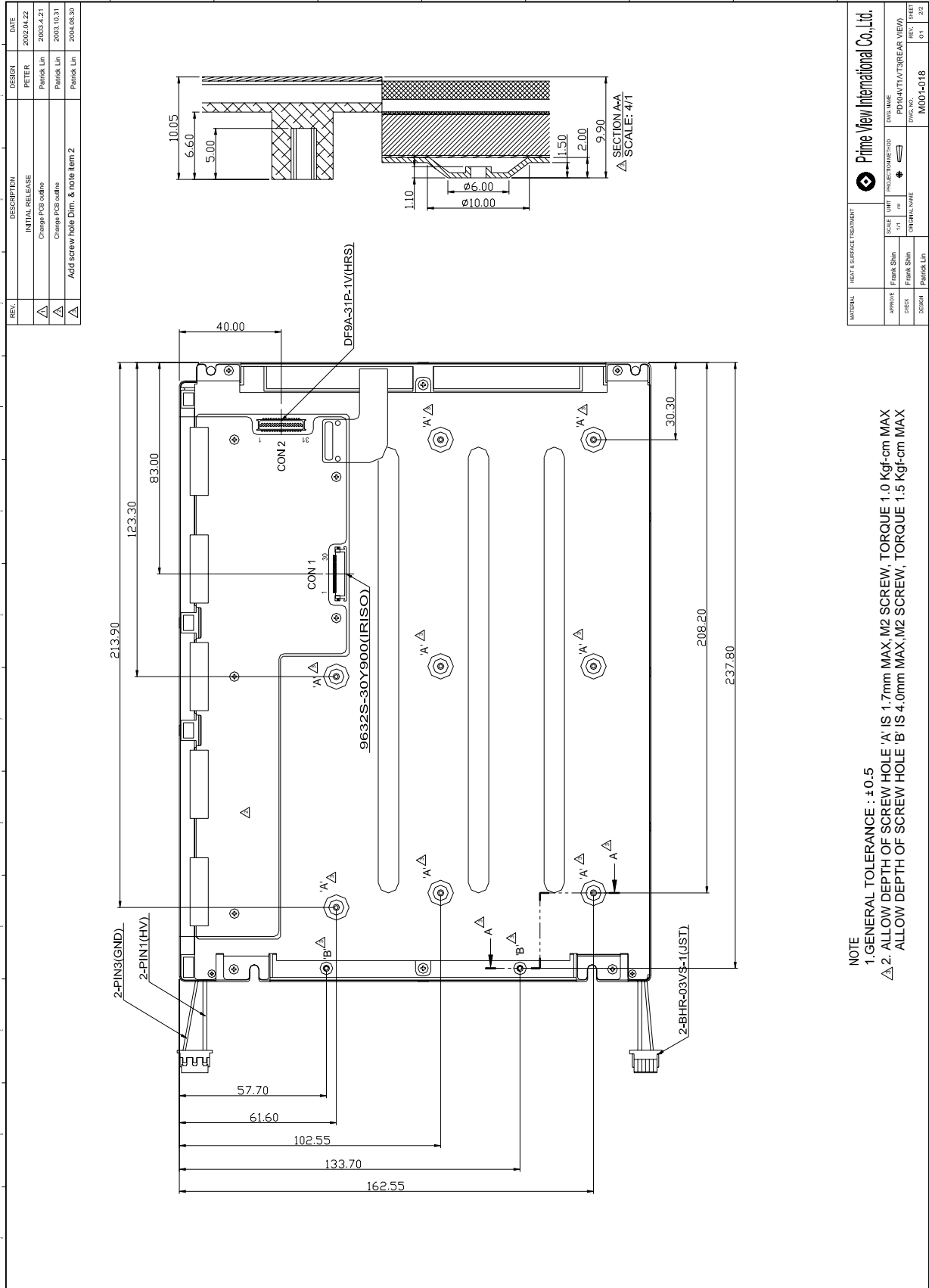

5.Input / Output Terminals

5-1) TFT-LCD Panel Driving

Connector type : IRISO , 9632S-30Y900 , PIN No.30 pin,pitch=0.5mm

Pin No.	Symbol	Function	Remark
1	CLK	Clock Signal for Sampling Image Digital Data	
2	Hsync	Horizontal Synchronous Signal	
3	Vsync	Vertical Synchronous Signal	
4	GND	Ground (0V)	
5	R0	Red Image Data Signal (LSB)	
6	R1	Red Image Data Signal	
7	R2	Red Image Data Signal	
8	R3	Red Image Data Signal	
9	R4	Red Image Data Signal	
10	R5	Red Image Data Signal (MSB)	
11	GND	Ground (0V)	
12	G0	Green Image Data Signal (LSB)	
13	G1	Green Image Data Signal	
14	G2	Green Image Data Signal	
15	G3	Green Image Data Signal	
16	G4	Green Image Data Signal	
17	G5	Green Image Data Signal (MSB)	
18	GND	Ground (0V)	
19	B0	Blue Image Data Signal (LSB)	
20	B1	Blue Image Data Signal	
21	B2	Blue Image Data Signal	
22	B3	Blue Image Data Signal	
23	B4	Blue Image Data Signal	
24	B5	Blue Image Data Signal (MSB)	
25	GND	Ground (0V)	
26	DENB	Data Enable Signal	Note 5-1 Note 5-2
27	VCC	DC +3.3V Power Supply	
28	VCC	DC +3.3V Power Supply	
29	R/L U/D	Horizontal Image Shift-direction Select Signal Vertical Image Shift-direction Select Signal	Note 5-3
30	GND	Ground (0V)	Note 5-4

Note 5-1 : The relationship between DENB & SYNC. mode

1. DENB mode with the top priority.
2. When working with the SYNC. mode , The Hsync and Vsync determine the timings.
3. This pin must connect to ground, if without DENB.

Mode	DENB	VGA
SYNC. Hsync Polarization	Don't care	Negative
Vsync Polarization	Don't care	Negative

Note 5-2 : DENB input signal.

If customer wanted to off the DENB mode , you must keep the DENB (pin 26) always High or Low.

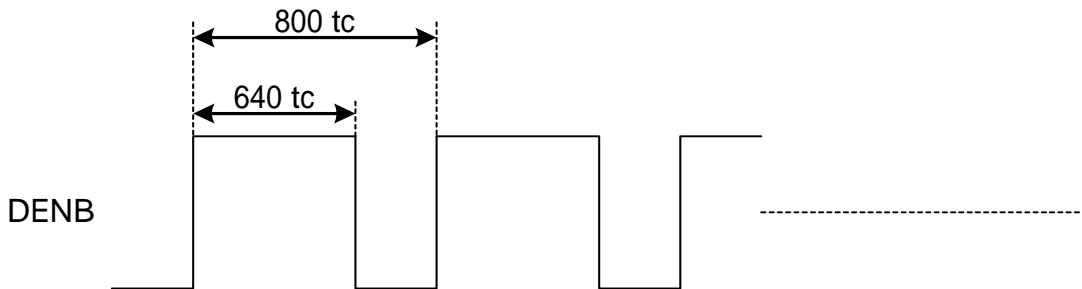

tc: the period of sample clock.

Note 5-3 : The definitions of U/D & R/L

U/D & R/L (PIN 29)= High

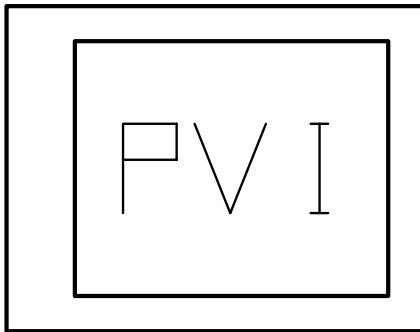

U/D & R/L (PIN 29)= Low

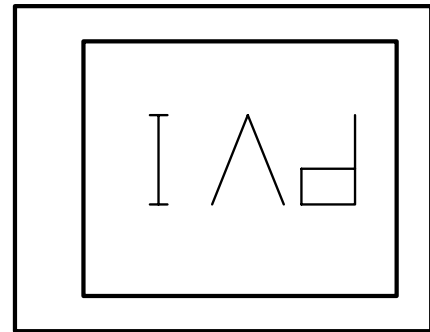

Note 5-4: This pin must connect to ground, if without grounding the panel can't turn on

5-2) Backlight driving

Connector type: BHR-03VS-1 (JST) , PIN No .3pin, pitch=4mm

Pin No	Symbol	Description	Remark
1	VL1	Input terminal (Hi voltage side)	Wire color : Pink
2	NC	No Connection	
3	VL2	Input terminal (Low voltage side)	Wire Color : White Note 5-3

Note 5-5 : Low voltage side of backlight inverter connects with ground of inverter circuits.

6. Absolute Maximum Ratings :

The followings are maximum values , which if exceeded, may cause faulty operation or damage to the unit.

GND=0V, Ta=25

Parameters	Symbol	MIN.	MAX.	Unit	Remark
Supply Voltage	V _{CC}	-0.3	+4.0	V	
Input Signal Voltage	V _{IN}	-0.3	V _{CC} +0.3	V	Note 6-1
Backlight Driving Voltage	V _L	-	2000	V	
Backlight Driving Frequency	F _L	0	100	KHz	

Note 6-1 : Input signals include CLK , Hsync , Vsync , DENB , R[0:5] , G[0:5] and B[0:5].

7. Electrical Characteristics

7-1) Recommended Operating Conditions:

GND = 0V , Ta = 25

Item	Symbol	Min.	Typ.	Max.	Unit	Remark	
Supply Voltage	V _{CC}	3.0	3.3	3.6	V		
Current Dissipation	I _{CC}	-	300	390	mA	Note 7-1	
Digital input voltage	H level	V _{IN}	0.7 V _{CC}	-	V _{CC}	V	
	L level	V _{IL}	-0.1	-	0.1 V _{CC}	V	
Lamp Current	I _{FL}	3.0	6.0	8.0	mA	Per CCFL Note 7-2 Note 7-4	
Lamp Voltage	V _L	486	540	594	Vrms	Note 7-2	
Starting Voltage (25) (Reference Value)	V _s	-	-	1080	Vrms	Note 7-3	
Starting Voltage (0) (Reference Value)	V _s	-	-	1410			
Lamp Driving Frequency	F _L	50	60	70	KHz	Note 7-5	

Note 7-1 : To test the current dissipation of V_{CC}, using the “color bars” testing pattern shown as below

1	2	3	4	5	6	7	8
---	---	---	---	---	---	---	---

1. White
2. Yellow
3. Cyan
4. Green
5. Magenta
6. Red
7. Blue
8. Black

I_{DD} current dissipation testing pattern

Note 7-2 : In order to satisfy the quality of B/L, no matter use what kind of inverter, the output lamp current must between Min. and Max. to avoid the abnormal display image caused by B/L.

Note 7-3 : The " Max of starting voltage " means the minimum voltage of inverter to turn on the CCFL. and it should be applied to the lamp for more than 1 second to start up. Otherwise the lamp may not be turned on.

PVI strongly recommend that the minimum voltage of inverter could be designed for 0°C condition.

Note 7-4 : Lamp current is measured with current meter for high frequency as shown below

Lamp current dissipation testing configuration

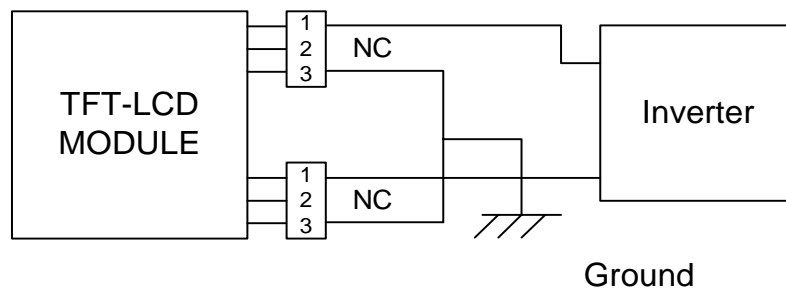

Note1:Pin 1 is high voltage,Pin 2 NC, Pin 3 ground.

Note2:One Lamp Current is 6mA.Two Lamp 12mA.

Note 7-5: The waveform of lamp driving voltage should be as closed to a perfect sine wave as possible.

7-2) Input / Output signal timing chart

Parameters		Symbol	Min.	Typ.	Max.	Unit	Note	
CLK	Frequency	$F_c=1/t_c$		25.175		MHz	Note 7-5	
		t_c		40		ns		
Hsync	Period	Hp		31.778		us		
				800		tc		
	Display period	Hdp		640		tc		
	Pulse width	Hpw	12	96	139	tc		
	Back-porch	Hbp	12	48	139	tc		
	Front-porch	Hfp		16		tc		
	Hpw+Hbp			136	144	151	tc	
	Hsync-CLK	Hhc	10		Tc-10	ns		
Vsync-Hsync	Hvh	0	0	200	tc			
Vsync	Period	Vp		16.8		ms		
			515	525	800	Hp		
	Display period	Vdp		480		Hp		
	Pulse width	Vpw	2	2	35	Hp		
	Back-porch	Vbp	2	33	35	Hp		
	Front-porch	Vfp	1	10		Hp		
Vpw+Vbp			31	35	38	Hp		
Data	CLK-DATA	Dcd	10			ns		
	DATA-CLK	Ddc	10			ns		
DENB	Horizontal scanning period	T1	780	800	900	tc		
	Horizontal display period	T2		640		tc		
	Vertical display period	T3		480		T1		
	Frame cycling period	T4	515	525	800	T1		

Note 7-5 : Tc is the period of sampling clock. In case of low-frequency , the image-flicker may occur.

7-3) Display Time Range

(1) Vertical Timing :

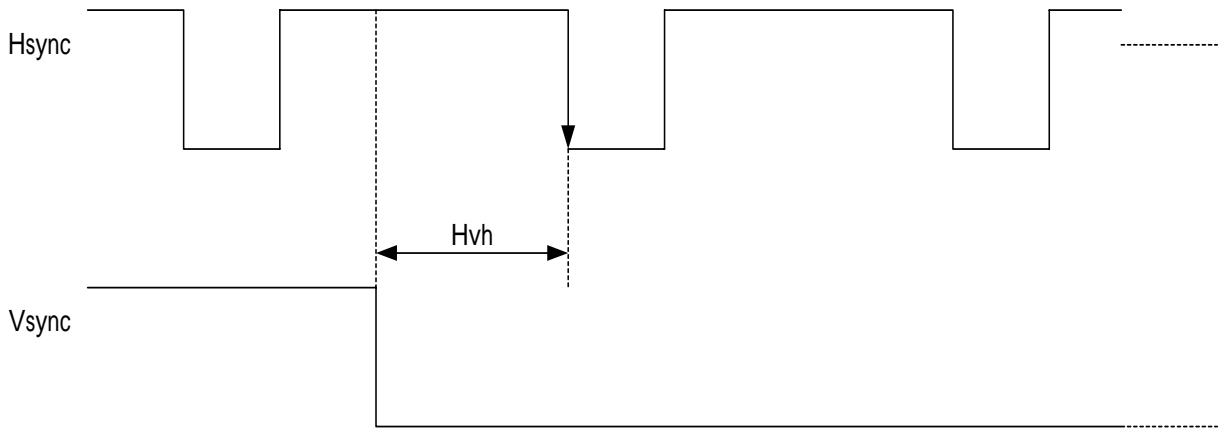

(2) Horizontal Timing :

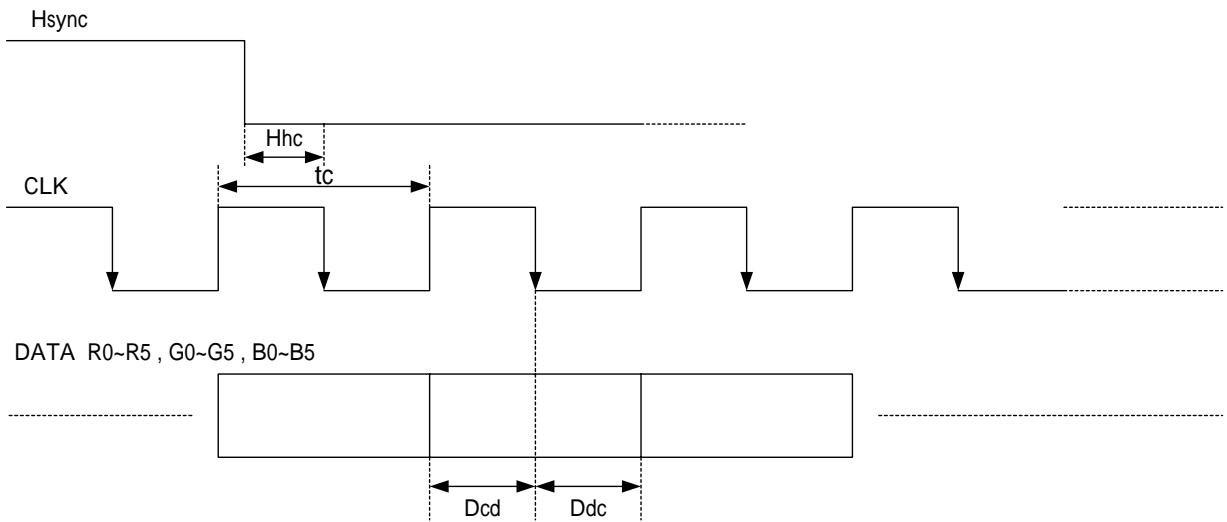

(3) DENB Timing :

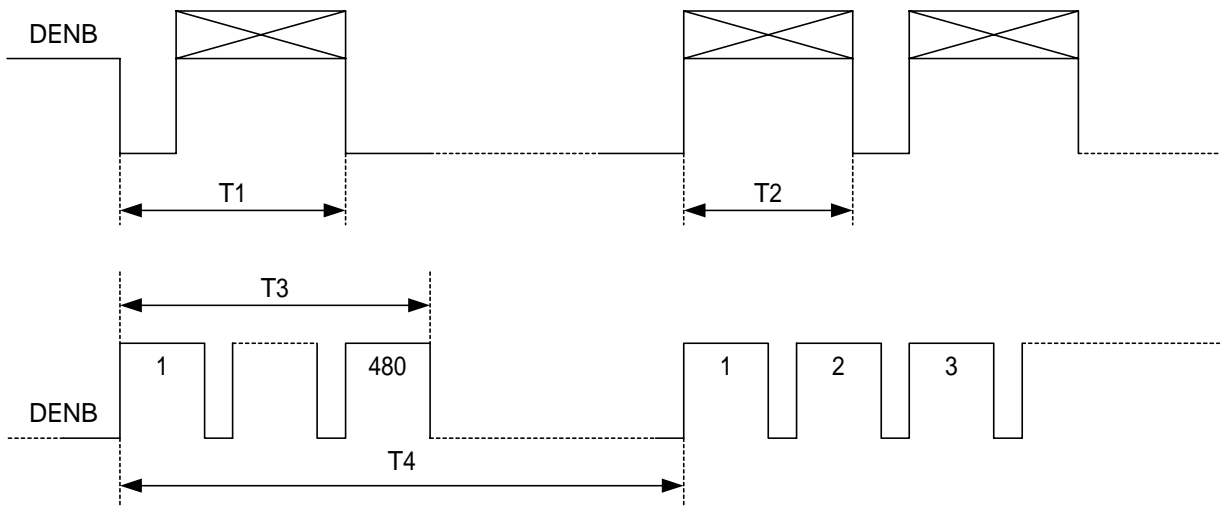

(4) Detail of Horizontal Timing :

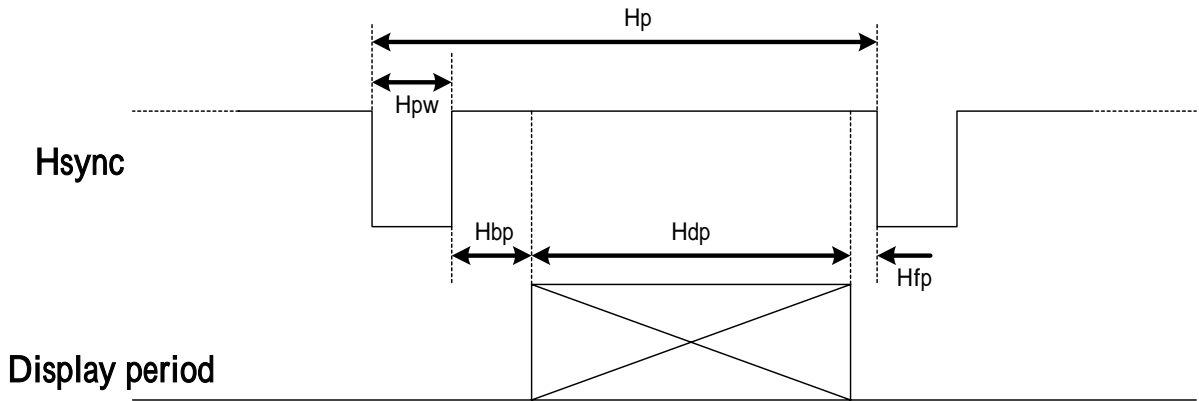

Item	Description	Clock Cycles	Time
Hpw	Horizontal Width	96	3.813 μ s
Hbp	Horizontal B-Porch	48	1.907 μ s
Hdp	Horizontal Display	640	25.422 μ s
Hfp	Horizontal F-Porch	16	0.636 μ s
Hp	Horizontal Total	800	31.778 μ s

(5) Detail of Vertical Timing :

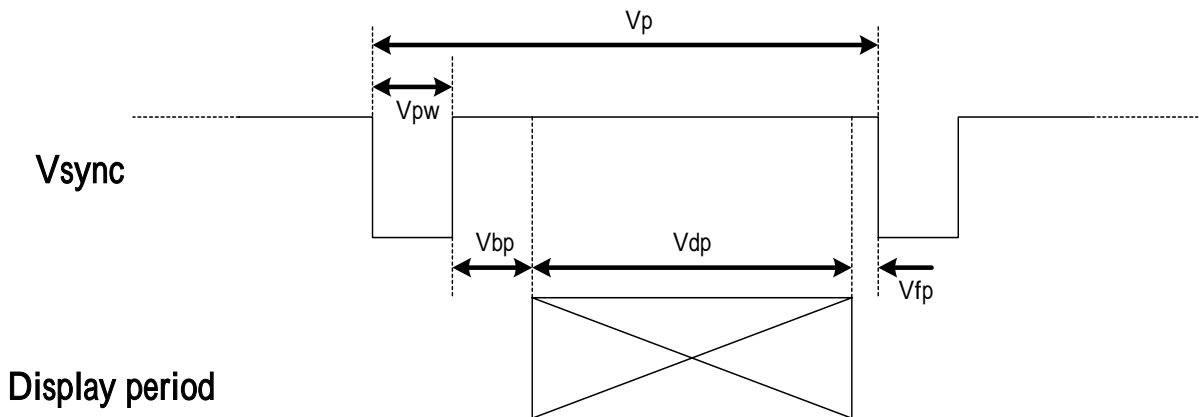

Item	Description	Horizontal Lines	Time
Vpw	Vertical Width	2	63.5 μ s
Vbp	Vertical B-Porch	33	1.049 ms
Vdp	Vertical Display	480	15.253 ms
Vfp	Vertical F-Porch	10	317.8 μ s
Vp	Vertical Total	525	16.683 ms

7-5) Display Color and Gray Scale Reference

Color		Input Color Data																	
		Red						Green						Blue					
		R5	R4	R3	R2	R1	R0	G5	G4	G3	G2	G1	G0	B5	B4	B3	B2	B1	B0
Basic Colors	Black	0	0	0	0	0	0	0	0	0	0	0	0	0	0	0	0	0	0
	Red (63)	1	1	1	1	1	1	0	0	0	0	0	0	0	0	0	0	0	0
	Green (63)	0	0	0	0	0	0	1	1	1	1	1	1	0	0	0	0	0	0
	Blue (63)	0	0	0	0	0	0	0	0	0	0	0	0	1	1	1	1	1	1
	Cyan	0	0	0	0	0	0	1	1	1	1	1	1	1	1	1	1	1	1
	Magenta	1	1	1	1	1	1	0	0	0	0	0	0	1	1	1	1	1	1
	Yellow	1	1	1	1	1	1	1	1	1	1	1	1	0	0	0	0	0	0
	White	1	1	1	1	1	1	1	1	1	1	1	1	1	1	1	1	1	1
Red	Red (00)	0	0	0	0	0	0	0	0	0	0	0	0	0	0	0	0	0	0
	Red (01)	0	0	0	0	0	1	0	0	0	0	0	0	0	0	0	0	0	0
	Red (02)	0	0	0	0	1	0	0	0	0	0	0	0	0	0	0	0	0	0
	Darker																		
	Brighter																		
	Red (61)	1	1	1	1	0	1	0	0	0	0	0	0	0	0	0	0	0	0
	Red (62)	1	1	1	1	1	0	0	0	0	0	0	0	0	0	0	0	0	0
	Red (63)	1	1	1	1	1	1	0	0	0	0	0	0	0	0	0	0	0	0
Green	Green (00)	0	0	0	0	0	0	0	0	0	0	0	0	0	0	0	0	0	0
	Green (01)	0	0	0	0	0	0	0	0	0	0	0	1	0	0	0	0	0	0
	Green (02)	0	0	0	0	0	0	0	0	0	0	1	0	0	0	0	0	0	0
	Darker																		
	Brighter																		
	Green (61)	0	0	0	0	0	0	1	1	1	1	0	1	0	0	0	0	0	0
	Green (62)	0	0	0	0	0	0	1	1	1	1	1	0	0	0	0	0	0	0
	Green (63)	0	0	0	0	0	0	1	1	1	1	1	1	0	0	0	0	0	0
Blue	Blue (00)	0	0	0	0	0	0	0	0	0	0	0	0	0	0	0	0	0	0
	Blue (01)	0	0	0	0	0	0	0	0	0	0	0	0	0	0	0	0	0	1
	Blue (02)	0	0	0	0	0	0	0	0	0	0	0	0	0	0	0	0	1	0
	Darker																		
	Brighter																		
	Blue (61)	0	0	0	0	0	0	0	0	0	0	0	0	1	1	1	1	0	1
	Blue (62)	0	0	0	0	0	0	0	0	0	0	0	0	1	1	1	1	1	0
	Blue (63)	0	0	0	0	0	0	0	0	0	0	0	0	1	1	1	1	1	1

8. Pixel Arrangement

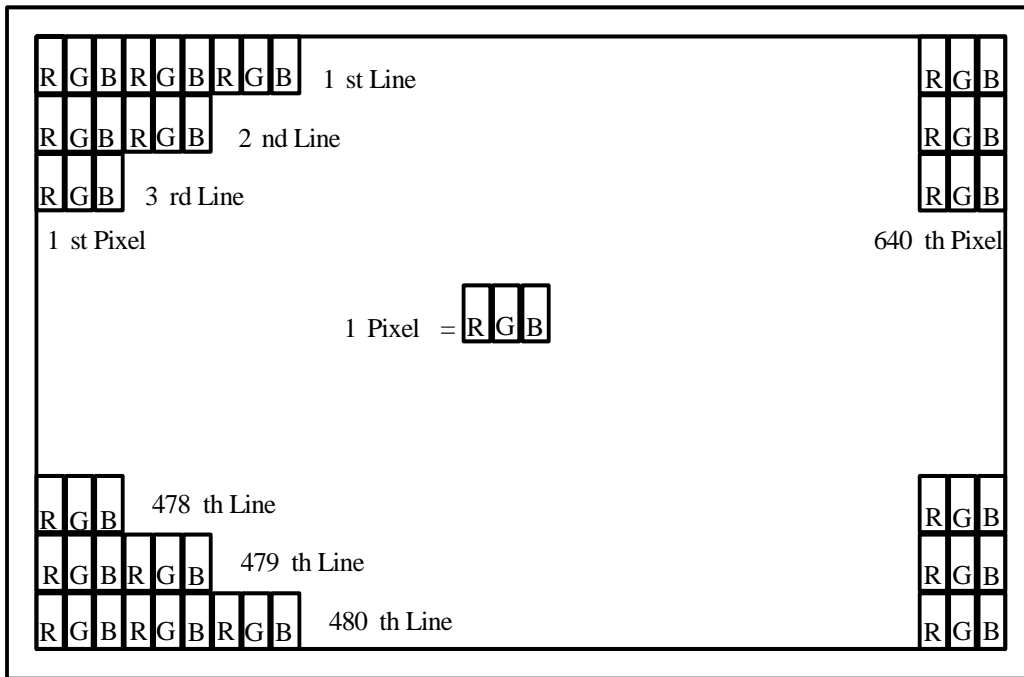

9. Power On Sequence

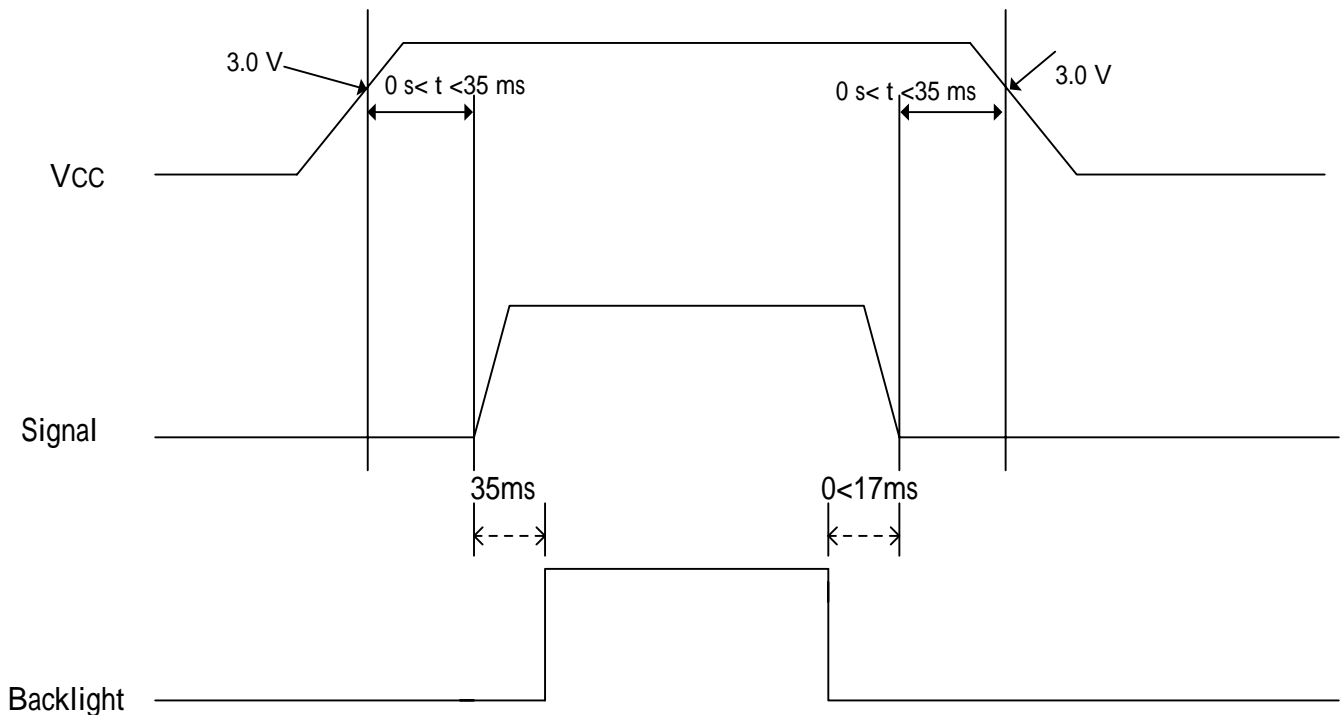

1. The supply voltage for input signals should be same as V_{CC} .
2. When the power is off , please keep whole signals (Hsync, Vsync, CLK, Data) low level or high impedance

10. Optical Characteristics

10-1) Specification:

Ta=25

Parameter	Symbol	Condition	MIN.	TYP.	MAX.	Unit	Remarks	
Viewing Angle	Horizontal	CR > 10	±55	±60	-	deg	Note 10-1	
	Vertical		(to 6 o'clock)	50	55	-		deg
			(to 12 o'clock)	35	40	-		deg
Contrast Ratio	CR		200	400	-	-	Note 10-2	
Response time	Rise	=0°	-	15	-	ms	Note 10-4	
	Fall		Tf	-	25	-		ms
Brightness		=0°/ =0	290	330	-	cd/m ²	Note 10-3	
Luminance Uniformity	U		70	80	-	%	Note 10-5	
Lamp Life Time			30000	-	-	hr		
White Chromaticity	x		0.279	0.309	0.339	-		
	y		0.307	0.337	0.367	-		
Cross Talk		=0°	-	-	3.5	%	Note10-6	

All the optical measurement shall be executed 30 minutes after backlight being turn-on. The optical characteristics shall be measured in dark room (ambient illumination on panel surface less than 1 Lux). The measuring configuration shows as following figure.

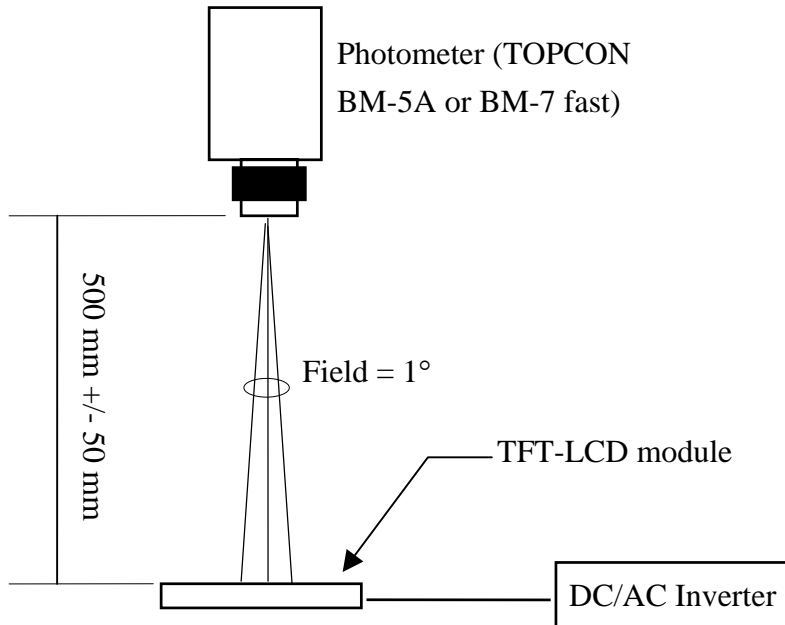

Optical characteristics measuring configuration

Note 10-1 : The definitions of viewing angles are as follow

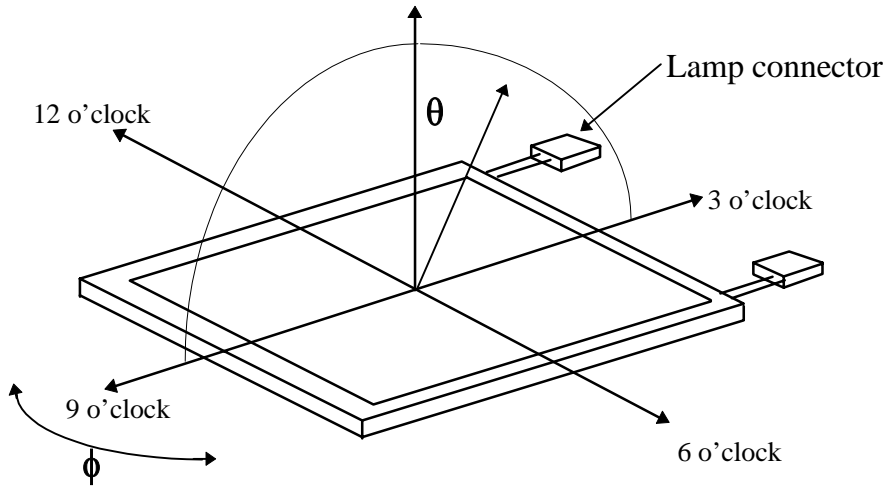

Note 10-2 : The definition of contrast ratio $CR = \frac{\text{Luminance at gray level 63}}{\text{Luminance at gray level 0}}$

Note 10-3 : Topcon BM-7 fast luminance meter 1°field of view is used in the testing (after 30 minutes' operation). The typical luminance value is measured at lamp current 12.0 mA.

Note 10-4: Definition of Response Time T_r and T_f :

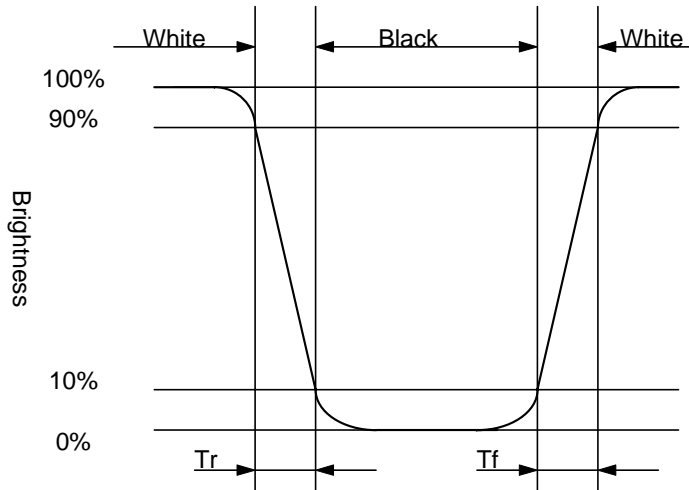

Note 10-5 : The uniformity of LCD is defined as

$$U = \frac{\text{The Minimum Brightness of the 9 testing Points}}{\text{The Maximum Brightness of the 9 testing Points}}$$

Luminance meter : BM-5A or BM-7 fast (TOPCON)

Measurement distance : 500 mm +/- 50 mm

Ambient illumination : < 1 Lux

Measuring direction : Perpendicular to the surface of module

The test pattern is white (Gray Level 63).

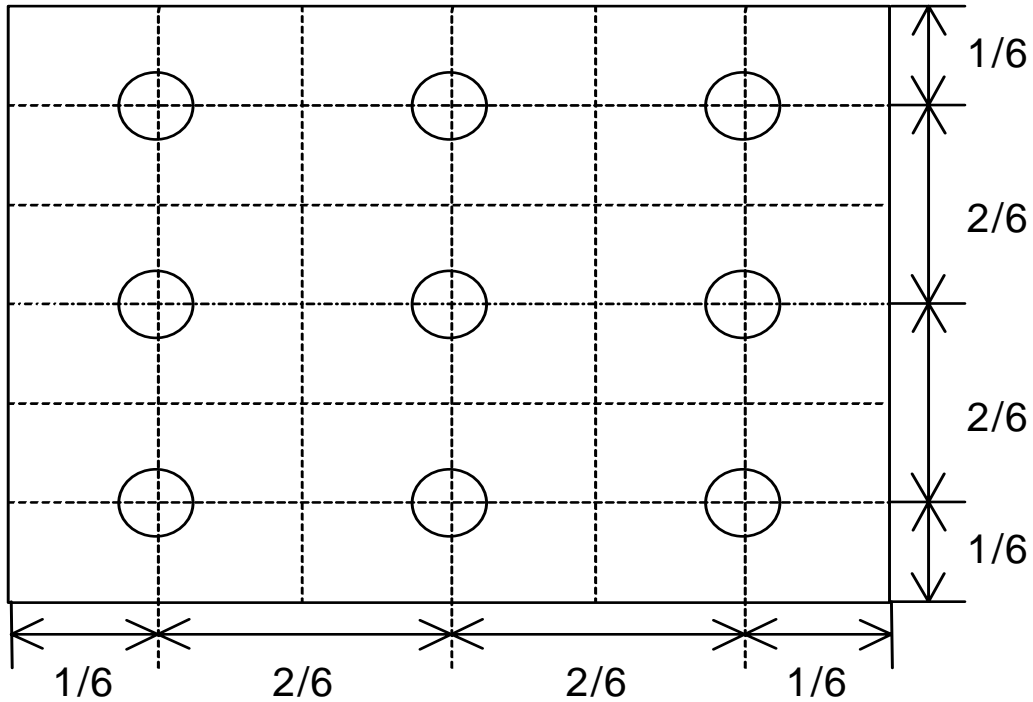

Note 10-6 : Cross Talk (CTK) = $\frac{|YA-YB|}{YA} \times 100\%$

YA : Brightness of Pattern A

YB : Brightness of Pattern B
Pattern A

(Gray Level 31)

Pattern B

(Gray Level 31, central
black box exclusive)

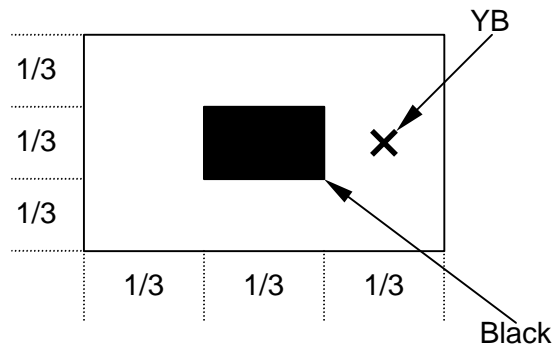
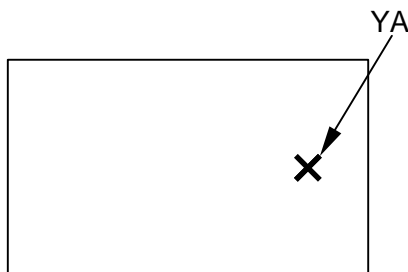

X: Testing Point (A and B are at the same point.)

(Gray Level 0)

11. Handling Cautions**11-1) Mounting of module**

- a) Please power off the module when you connect the input/output connector.
- b) Please connect the ground pattern of the inverter circuit surely. If the connection is not perfect, some following problems may happen possibly.
 - 1. The noise from the backlight unit will increase.
 - 2. The output from inverter circuit will be unstable.
 - 3. In some cases a part of module will heat.
- c) Polarizer which is made of soft material and susceptible to flaw must be handled carefully.
- d) Protective film (Laminator) is applied on surface to protect it against scratches and dirt. It is recommended to peel off the laminator before use and taking care of static electricity.

11-2) Precautions in mounting

- a) When metal part of the TFT-LCD module (shielding lid and rear case) is soiled, wipe it with soft dry cloth.
- b) Wipe off water drops or finger grease immediately. Long contact with water may cause discoloration or spots.
- c) TFT-LCD module uses glass which breaks or cracks easily if dropped or bumped on hard surface. Please handle with care.
- d) Since CMOS LSI is used in the module. So take care of static electricity and earth yourself when handling.

11-3) Adjusting module

- a) Adjusting volumes on the rear face of the module have been set optimally before shipment.
- b) Therefore, do not change any adjusted values. If adjusted values are changed, the specifications described may not be satisfied.

11-4) Others

- a) Do not expose the module to direct sunlight or intensive ultraviolet rays for many hours.
- b) Store the module at a room temperature place.
- c) The voltage of beginning electric discharge may over the normal voltage because of leakage current from approach conductor by to draw lump read lead line around.
- d) If LCD panel breaks, it is possibly that the liquid crystal escapes from the panel. Avoid putting it into eyes or mouth. When liquid crystal sticks on hands, clothes or feet. Wash it out immediately with soap.
- e) Observe all other precautionary requirements in handling general electronic components.
- f) Please adjust the voltage of common electrode as material of attachment by 1 module.

11-5) Polarizer mark

The polarizer mark is to describe the direction of wide view angle film how to match up with the rubbing direction.

12. Reliability Test

No	Test Item	Test Condition	Remark
1	High Temperature Storage Test	Ta = +70 , 240 hrs	
2	Low Temperature Storage Test	Ta = -20 , 240 hrs	
3	High Temperature Operation Test	Ta = +60 , 240 hrs	
4	Low Temperature Operation Test	Ta = -10 , 240 hrs	
5	High Temperature & High Humidity Operation Test	Ta = +60 , 90%RH, 240 hrs (No Condensation)	
6	Thermal Cycling Test (non-operating)	0 → +60 , 50 Cycles 1Hr 1Hr	
7	Vibration Test (non-operating)	Frequency : 10 ~ 57 Hz, Amplitude : 0.5 mm 58~500Hz, 1G Sweep time: 11 min Test Period: 3 hrs (1 hr for each direction of X, Y, Z)	
8	Shock Test (non-operating)	80G, 6ms, X,Y, Z 1 times for each direction	
9	Electrostatic Discharge Test (non-operating)	150pF, 330 Air: ±15KV; Contact: ±8KV 10 times/point, 9 points/panel face	

Ta: ambient temperature

Note 12-1 : The protective film must be removed before temperature test.

[Criteria]

1. Main LCD should normally work under the normally condition no defect of function, screen quality and appearance (including : mura ,line defect ,no image)
2. After the temperature and humidity test, the luminance and CR (Contrast ratio) ,should not be lower than minimum of specification
3. After the vibration and shock test , can't be find chip ,broken.

13. Block Diagram

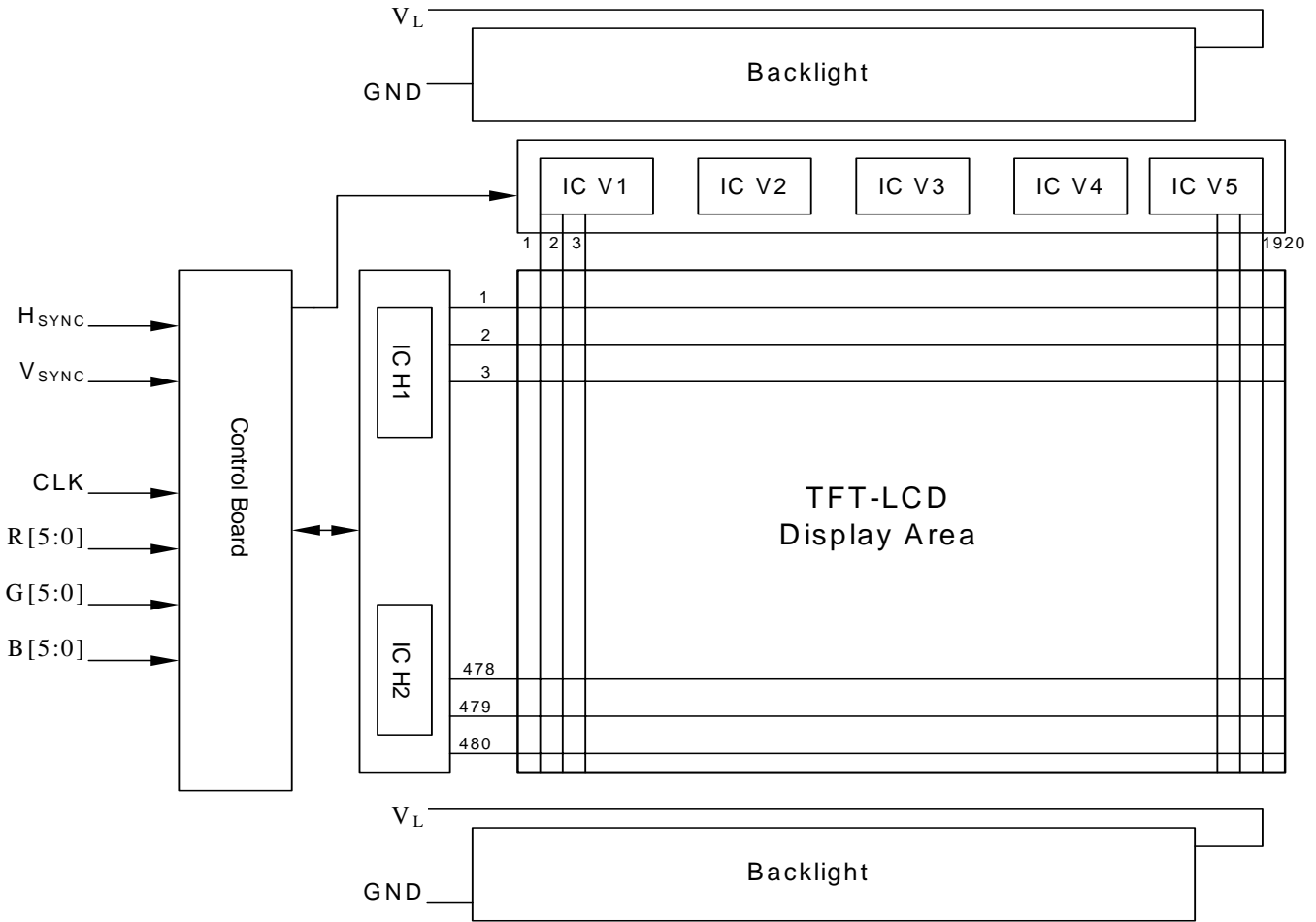

14. Packing Diagram

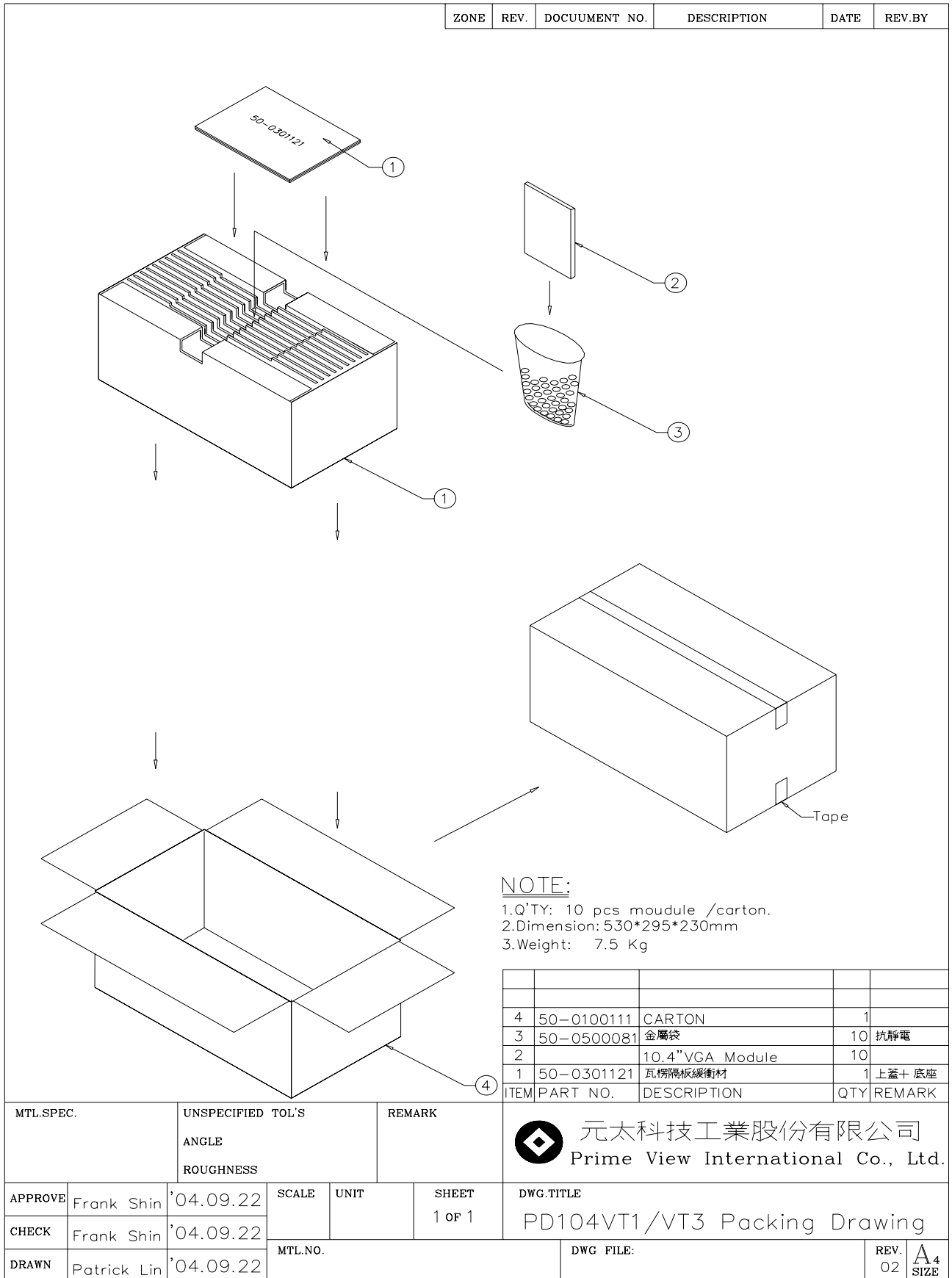

Revision History

Rev.	Issued Date	Revised Contents
1.0	Dec 11,2002	New
1.1	Mar. 18,2003	Modify Page 5 : Mechanical Drawing(change PCBA outline dimension) Page 6 : TFT-LCD Panel Driving (pin 30 must connect to ground) Page 7-3 : Input / Output signal timing chart (Back Porch form 49 to 48) Page 17 : Reliability test (High Temperature & High Humidity Operation Test from 60 ,95%RH to 60 ,90%RH)
1.2	Mar. 31,2003	Add Page 17 : 10.Handling Cautions Page 18 : 12. Indication of Lot Number Label
1.3	May. 28,2003	Add Page 7 : 7-1 Recommended Operating Conditions (Digital input voltage) Page 14 : 9. Optical Characteristics (Luminance uniformity from 50%(min.) to 70%(min.) Page 17 : 11. Reliability Test(Low Temperature Operation test from 0 to -10)
1.4	Aug. 26 ,2003	Modify Page 4 : 4.Mechanical Drawing of TFT-LCD Module (point the warranty label position) Page 9 : 7-4 Display Time Range(remove positive input signal) Page 18 : 11. Reliability Test(remove low temperature storage test) Page 18 12. Indication of Lot Number Label
1.5	Nov. 25 ,2003	Modify Page 4,5 : Mechanical Drawing Page 16 : Contrast Ratio (CR fromTyp.180,Min.100 to Typ.400,Min.200) Page 20 : Indication of Lot Number Label Page 8 : Electrical Characteristics a.Input/Output signal timing chart b.Display Time Range Add Page 6 : Support the DENB mode & Image Reversion : Up/Down and Left/Right
1.6	May. 18,2004	Modify Page 7 : Note 5-2 : DENB input signal
1.7	Sep. 14,2004	Modify Page 5 : Mechanical Drawing
1.8	Sep. 30,2004	Modify Page 3: 3.Mechanical Specifications Surface treatment Page 21 : Packing Diagram Page 9 : Note 7-3 Add Lamp kick –off time

1.9	Jan. 17,2005	Del Page 19 : 12. Indication of Lot Number Label
2.0	Jan.13,2006	Add Page 6: Note5-5 Page 19: Low Temperature Storage Test -20 High Temperature Operation Test +60 Modify Page8: 7.Electrical Characteristics 7-1) Recommended Operating Conditions Starting Voltage (25) (Reference Value) from 1060 change to 1080 Vrms Starting Voltage (0) (Reference Value) from 1300 change to 1410 Vrms Page 19: Criteria